

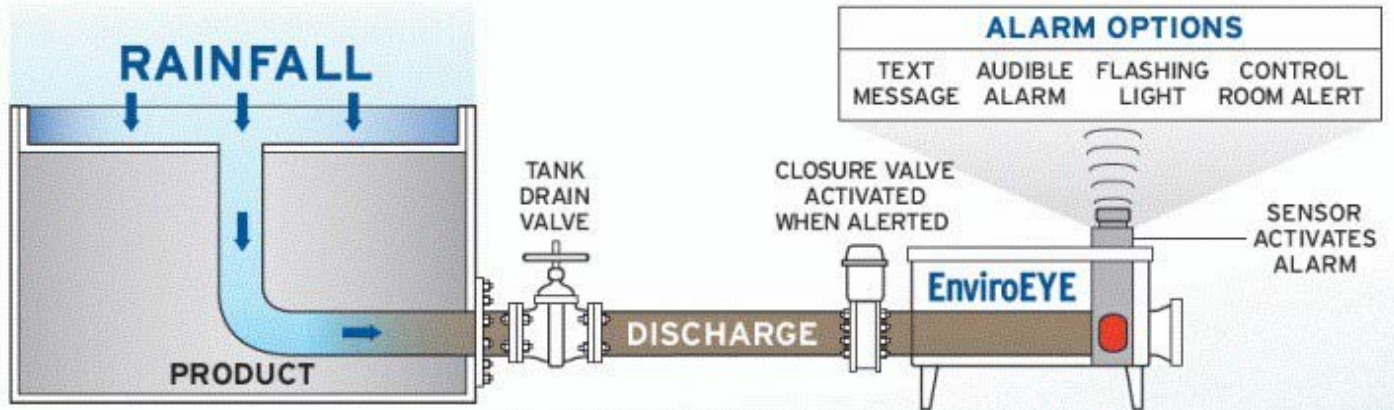

Catch a weep before it is a leak.
Catch a leak before it is a spill.

EnviroEye Drain Guard System (EE DGS)

The **EnviroEye Drain Guard System (EE DGS, Patent 2020)** continuously monitors storm water for hydrocarbon sheen, allowing safe drainage without disrupting tank operations. Installed directly by flange, the EE DGS is a simple, non-intrusive solution that helps prevent unintentional releases while providing proactive environmental protection. Best of all, it can be installed without taking the asset out of service—keeping your operations running smoothly.



Key Advantages

- Constantly drain storm water – leave roof drain open
- Semi-Automated roof drainage with alerts
- Minimize operator time in inclement weather
- Protect your investment



Applications & Configurations

- External Floating Roof Tanks (EFRTs)
- Dike Outfalls
- Sumps for Railcars, Truck Racks, & Dock Lines
- Contact Water Tanks
- Well Heads

Sustainable Operations

- Reduce site contamination
- Protect the environment
- Demonstrate environmental responsibility and initiative
- Minimize product loss
- Routine preventative maintenance

Options & Customization

- Motor Operated Valve (MOV)
- Hydrocarbon Sensor - Slick Sleuth
- Cold Weather Package
- Beacon (Visual Alert)
- Horn (Audible Alert)
- Bypass Manifold
- Flow Indicator
- Control Room Integration
- Text Message Notification
- Will match your AVML
- C1d1 rated equipment
- Secondary MOV
- Secondary Filter Chamber

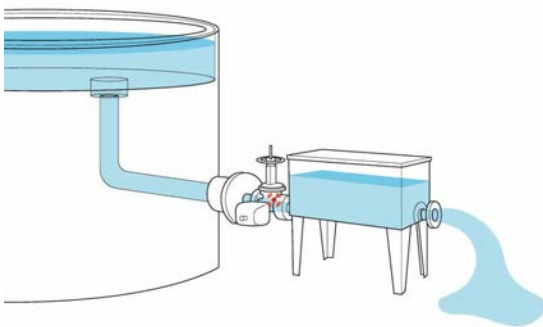

EFRTs

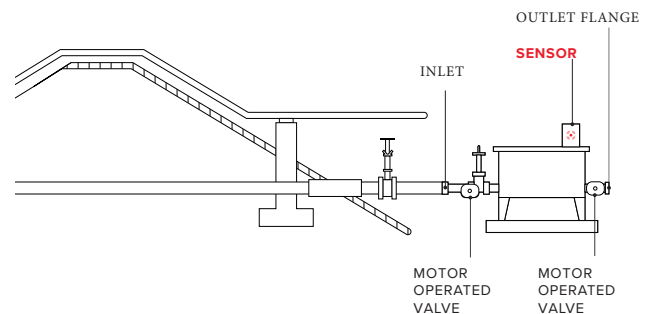

Dike Outfalls

EnviroEye, LLC - Drain Guard Systems

4635 Southwest Freeway, Suite 910, Houston, TX 77027

Phone: (713) 627-1700 ext. 106 Fax: (713) 621-9292

Email: sales@enviroeye.net Website: www.enviroeye.net